

Xfeed

hhs
Baumer Group

Process optimisation for
your packaging lines

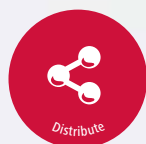
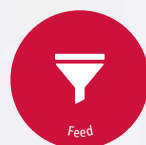

Xfeed *hot melt feeding
on demand*

Let's stick together

baumerhhs.com

Xfeed – Process optimisation for your packaging lines



Messy production area with spilled hot melt adhesive granules

Centralised adhesive supply for an entire packaging production system.

The new Xfeed from Baumer hhs is the world's first system to finally supply adhesive to all the hot melt units in a facility. The adhesive granules are distributed even across long distances from the storage area to the devices, which are then filled automatically.

The heart of the system, the Xfeed centre, calculates the amount of adhesive required by all connected devices using intelligent sensor and control technology, ultimately maximising the availability of your packaging lines and guaranteeing continuous production. Downtime caused by inadequate fill levels, or by work required to clean up spilled adhesive granules, becomes a thing of the past.

Production automation done in this way results in optimally glued packages every time. Eliminating manual filling of the individual hot melt units cuts costs by up to 90%. Time-consuming cleaning of the production area becomes unnecessary, and operators can be assigned to other value-adding tasks.

Benefit now from optimum fill levels in your hot melt units.

Thanks to low and constant fill level, the adhesive is in optimum condition at all times, protected from charring by ensuring continuous consumption. This saves energy, increases occupational safety and minimises maintenance and servicing costs.

Melt on demand with Baumer hhs Xfeed.

This new system is manufacturer-independent, meaning it supports maximum flexibility in selecting production supplies. Xfeed is compatible with hot melt units from all manufacturers and therefore can easily be integrated into your existing production environment.

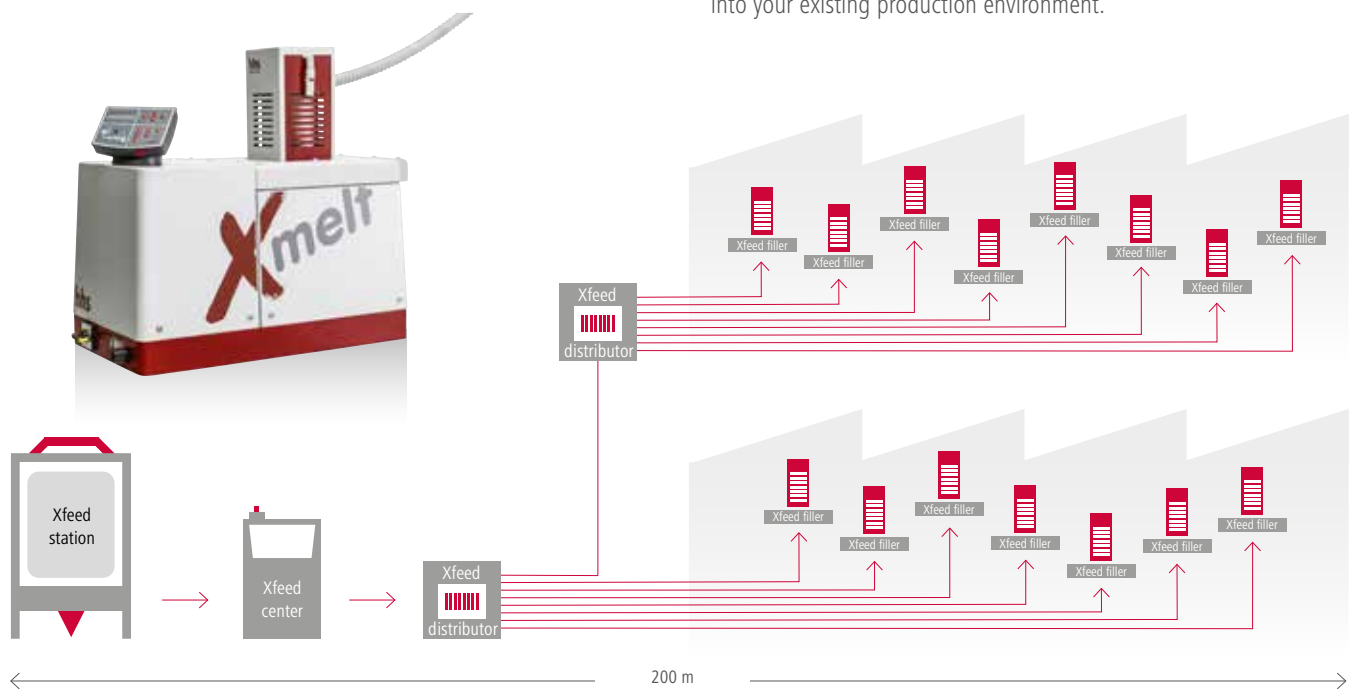

Advantages of Xfeed at a glance

- No manual refilling of the hot melt units, no risk of charring
- Cleanliness and industrial hygiene
- No granules in the production area
- Can be connected to hot melt units from all manufacturers
- Just one adhesive storage location required at the plant; handling of larger containers.
- Cuts cost of filling, maintenance and servicing by up to 90%
- Melt on demand for continuous production and preserving glue state
- More flexible use of space
- Adhesive granules can be transported over a distance of up to 200 m
- Modular system, can be flexibly expanded

Xfeed – The system components for perfect integration

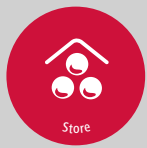

Xfeed bag station

This centralised adhesive supply station is ideally located outside the production area. It is available in two sizes depending on adhesive consumption rates (125 kg, 1000 kg). Vibration units reliably prevent the adhesive granules from clogging the storage container.



Xfeed distributor

The linearly operated Xfeed distributor is linked to the terminal devices. The adhesive granules delivered to it are distributed to the hot melt units based on current demand (configurable with 4 or 8 connections, as required by the application). The number of connected hot melt units can be flexibly increased to up to 20 by integrating additional Xfeed distributors.



Xfeed center

The heart of the system, the Xfeed centre is controlled via a touchscreen display backed by a high-tech intuitive control system. Demand-based feed of the adhesive granules is handled by the integrated feed tower, which transports them by means of compressed air to the Xfeed distributor. Depending on adhesive consumption rates, the configurable tower can feed between 0.5 litre and 10 litre of adhesive granules in a single conveying operation.



Xfeed filler

The adapter on a hot melt unit transports the granules to the melting tank. The fill level in the hot melt unit is measured by an adjustable capacitive sensor. The Xfeed filler is manufacturer-independent and entirely adaptable to customer needs.

Project development

During the joint project development phase for integrating Xfeed, the specialists from Baumer hhs will discuss all the necessary components required. For all units, we offer either custom piping to meet your needs or tubing certified by Baumer hhs. Our planning services further include connection of the units to the required media, i.e. compressed air and electric power.

In integrating the Xfeed from Baumer hhs into your system, you are putting your adhesive supply activities into safe hands and optimising your manufacturing process. The combination of intelligent software, sensor technology and long conveying distances increases productivity, occupational safety and cleanliness in your production environment.



Technical drawings

Xfeed big bag station

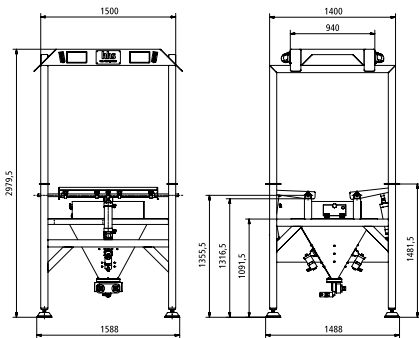

Xfeed bag station

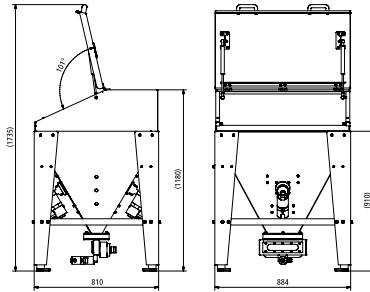

Xfeed center

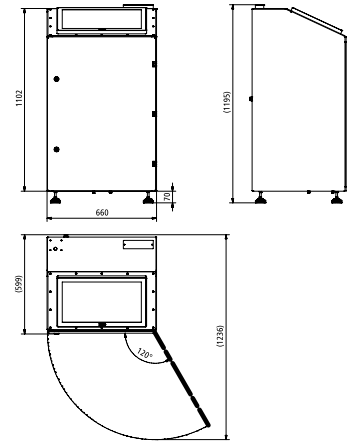

Xfeed filler

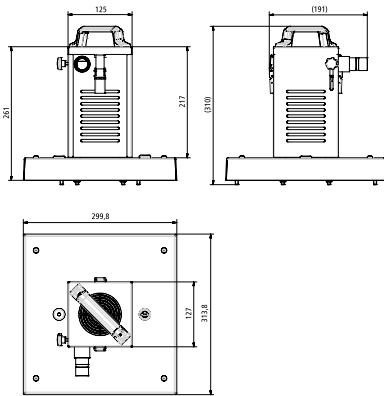

Xfeed distributor

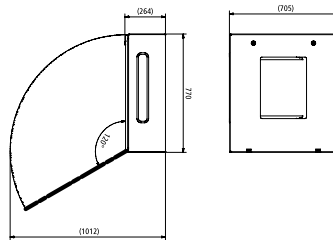

Full service

